

(MEGA FUSES, RING TERMINALS, SHRINK TUBING, AND BOOT FOUND IN 510476 KIT)

6 GA. RED (FROM 510476 KIT)

10 GA. RED (12 V BATTERY) (FROM 500668 KIT)

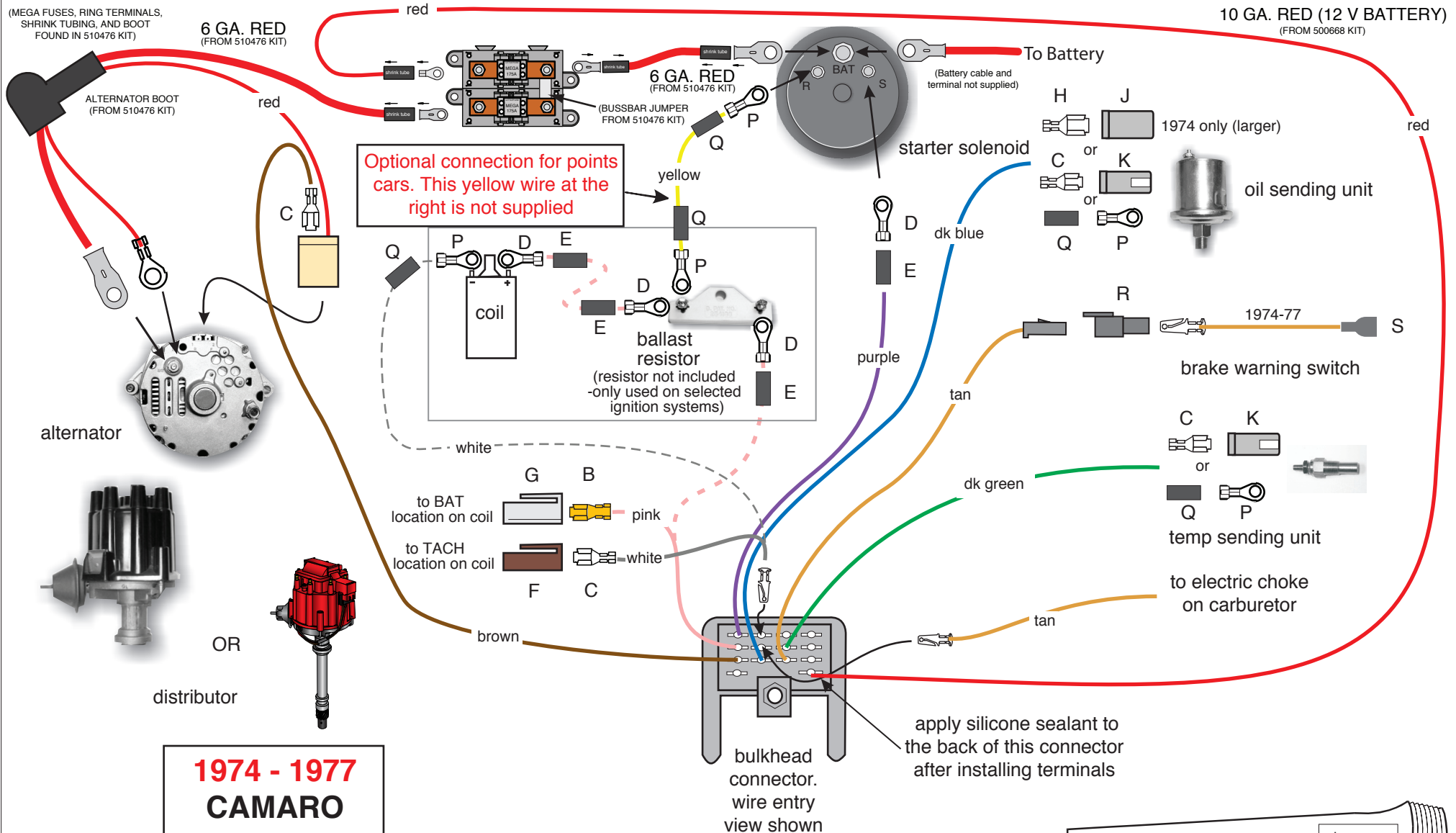

NOTE: Wiper connections are shown on pages 5 & 6 of this instruction set.



American Autowire

www.americanautowire.com 856-933-0801

Classic Update Series
1974-77 &
1978-80 Camaro
ENGINE KIT

510570

92970835 instruction rev 2.0 1/10/2018

bag

J

(MEGA FUSES, RING TERMINALS, SHRINK TUBING, AND BOOT FOUND IN 510476 KIT)

6 GA. RED (FROM 510476 KIT)

(RING TERMINALS AND SHRINK TUBING FOUND IN 510476 KIT)

6 GA. RED (FROM 510476 KIT)

(BUSBAR JUMPER FROM 510476 KIT)

10 GA. RED (12 V BATTERY) (FROM 500668 KIT)

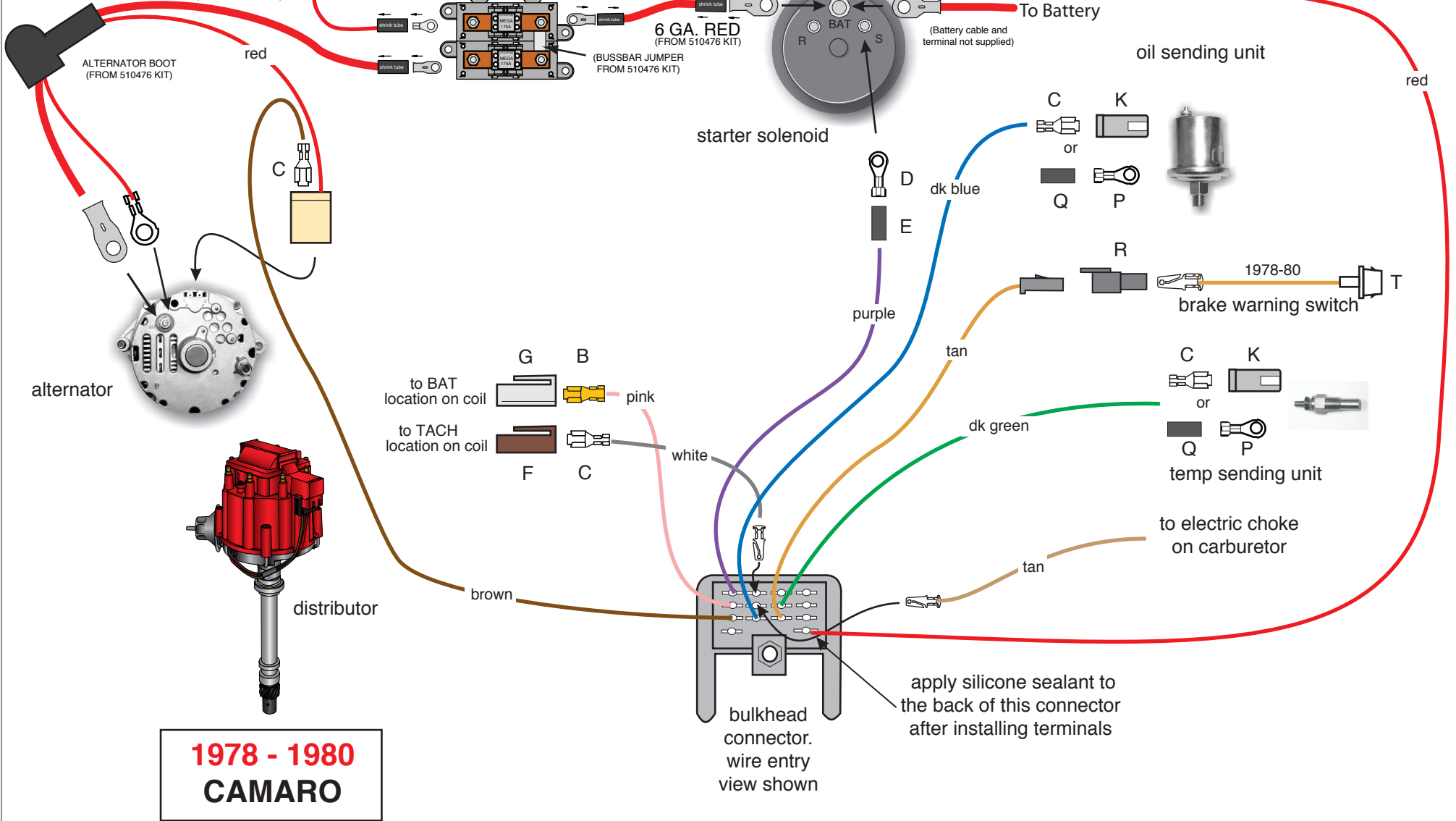

NOTE: Wiper connections are shown on pages 6 & 7 of this instruction set.



American Autowire

www.americanautowire.com 856-933-0801

**ENGINE KIT
510570**

92970835 instruction rev 2.0 1/10/2018

TEMPORARILY, PLUG THE MAIN BULKHEAD CONNECTOR FROM THIS KIT INTO THE MATING CONNECTOR ON THE DASH BULKHEAD CONNECTOR (LOCATED UNDER THE MASTER CYLINDER) Note: This will be unbolted to install the front light harness later.

BULKHEAD CONNECTOR WIRES:

PINK	(12 V IGNITION)	<p>If using a points type ignition system: Route the PINK wire to the ignition feed side of a ballast resistor (not included), cut to length, install rubber sleeve E and ring terminal D, and connect it to the ignition feed side of the ballast resistor as shown on page 1 of this instruction set. Install rubber sleeve E and ring terminal D onto the cut-off portion of this wire and connect it to the coil side of the ballast resistor (along with the yellow bypass wire [not supplied]) as shown on page 1 of this instruction set. Route the loose end of this wire to the positive post of the coil, cut to length, install rubber sleeve E and ring terminal D on that end of the wire, and install it onto the positive (+) post of the coil.</p> <p>If using an HEI type ignition system: Route this PINK wire to the coil, trim to length, install terminal B and connector G, then plug into the distributor cap "BAT" location as shown on page 1 of this instruction set.</p> <p>If using an aftermarket type 12v ignition system: Route this PINK wire to the 12v ignition connection location of your ignition system, trim to length, then connect it to the 12v ignition connection of your system (consult the ignition system manufacturer's instructions for specific installation procedures)</p>
RED	(12 V BATTERY)	Route this RED wire to the Megafuse and cut to length. Install the ring terminal and shrink tubing from the 510476 kit. Connect as shown on page 1 or page 2 of this instruction set.
PURPLE	(STARTER SOLENOID)	Route this PURPLE wire to the starter solenoid and cut to length. Install rubber sleeve E and ring terminal D. Connect to the "S" terminal on the solenoid as shown on page 1 or page 2 of this instruction set.
DARK BLUE	(OIL PRESSURE SENDER)	Route this DK. BLUE wire to the oil pressure sending unit, cut to length, install rubber sleeve R and ring terminal P, terminal C together with connector K, or terminal H together with connector J (1974 ONLY!), then connect it to the sending unit as shown on page 1 or page 2 of this instruction set.
DARK GREEN	(WATER TEMP SENDER)	Route this DK. GREEN wire to the temperature sending unit, cut to length, install rubber sleeve R and ring terminal P, or terminal C together with connector K, then connect it to the sending unit as shown on page 1 or page 2 of this instruction set.
<p>NOTE: You have been provided with two different brake pressure differential warning switch extensions (S for 1974-77, and T for 1978-80). If you are running an aftermarket, upgraded braking system on your pre-1978 car, your system may also utilize the later style extension T. Choose the proper extension for your application and plug connector R onto that lead. Plug his completed extension onto your brake pressure differential warning switch.</p>		
TAN	(BRAKE LIGHT SWITCH)	Route this TAN wire and connector assembly to the brake pressure differential switch as shown on page 1 or page 2 of this instruction set, then plug the connector onto your tan brake warning extension wire from above to complete this circuit.
BROWN	(ALTERNATOR IGN)	This is your alternator regulator exciter wire. If using a 1-wire alternator, this wire can be removed from the main connector, as it will not be used. If using with a GM "SI" internally regulated alternator, route this BROWN wire to the alternator, cut to length, and install terminal C. This wire will plug into the empty cavity in the off white alternator connector that has the SMALL RED wire already installed into it (from page 4) as seen on page 1 or 2 of this instruction set. Do not install this BROWN wire yet.

LOOSE PIECE WIRES cont'd on page 4:

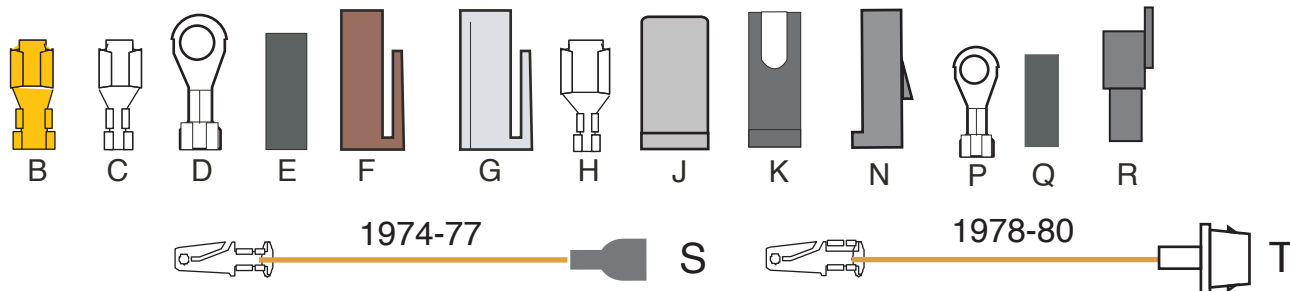

www.americanautowire.com 856-933-0801

ENGINE KIT
510570

92970835 instruction rev 2.0 1/10/2018

LOOSE PIECE WIRES Cont'd:

LOOSE PIECE WIRES:

TAN (ELECTRIC CHOKE)

Install this loose wire into main connector as shown on page 1 or page 2 of this instruction set, then route and connect this wire to your electric choke. No terminals have been provided for this connection.

WHITE (COIL-TACH)

Install this loose wire into main connector as shown on page 1 or page 2 of this instruction set, then route this WHITE wire to the coil and trim to length. If using an HEI distributor, install terminal C and connector F and then plug into the distributor cap "TACH" location. If using a conventional coil, install rubber sleeve R and ring terminal P and connect to the negative (-) post of the coil.

ALTERNATOR WIRES:

HEAVY RED (no printing)

Use the 6ga wire, ring terminals, shrink tubing, boot, Megafuses, and instructions from the 510476.

SMALL RED (no printing)

(Used only with a GM "SI" internally regulated alternator [except a 1-wire]) Send the ring terminal end of this wire through boot L as shown on page 1 or page 2 of this instruction set, and connect to the battery stud on the alternator. Install the BROWN exciter wire from above into the empty cavity of this connector and then plug this connector into the alternator as shown on page 1 or page 2 of this instruction set.

NOTE: See page 5, 6, or 7 for the wiper washer wire connections as they apply to your year and application.

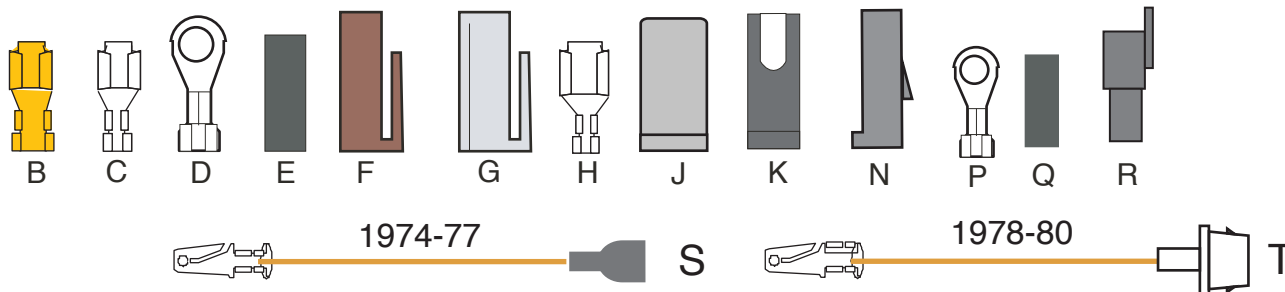

www.americanautowire.com 856-933-0801

ENGINE KIT
510570

92970835 instruction rev 2.0 1/10/2018



1974 Camaro models with 2 speed wipers and washers

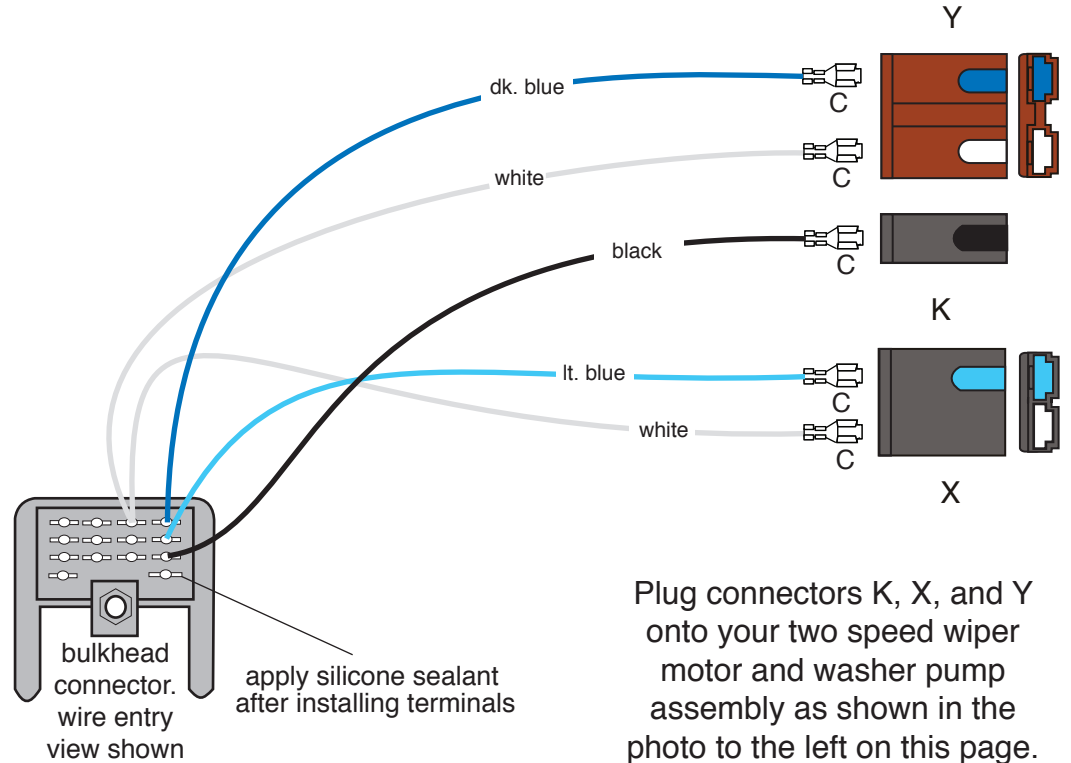

Plug connectors K, X, and Y onto your two speed wiper motor and washer pump assembly as shown in the photo to the left on this page.

WHITE (wiper feed)
(original black/yellow in photo)

Route the short white wire to the wiper motor, trim to length, install terminal C, and plug into connector X as shown on this page. Route the long white wire to the washer pump, trim to length, install terminal C, and plug into connector Y as shown on this page.

BLACK (wiper low speed)
(original black in photo)

Route this wire to the wiper motor, trim to length, install terminal C, and plug into connector K as shown on this page.

LT. BLUE (wiper high speed)
(original lt. blue in photo)

Route this wire to the wiper motor, trim to length, install terminal C, and plug into connector X as shown on this page.

DK. BLUE (washer)
(original dk. blue in photo)

Route this wire to the washer pump, trim to length, install terminal C, and plug into connector Y as shown on this page.

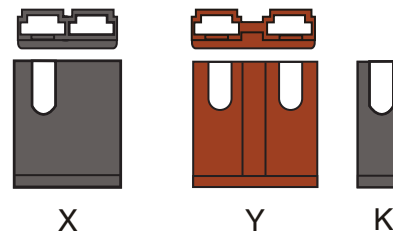

**1974 TWO
SPEED WITH
WASHER PUMP
CONNECTIONS**



**ENGINE KIT
510570**



1975-1978 Camaro models with 2 speed wipers and washers. (Wiper motor connection shown. Washer pump is remote, is not shown, but can only be plugged in one way).

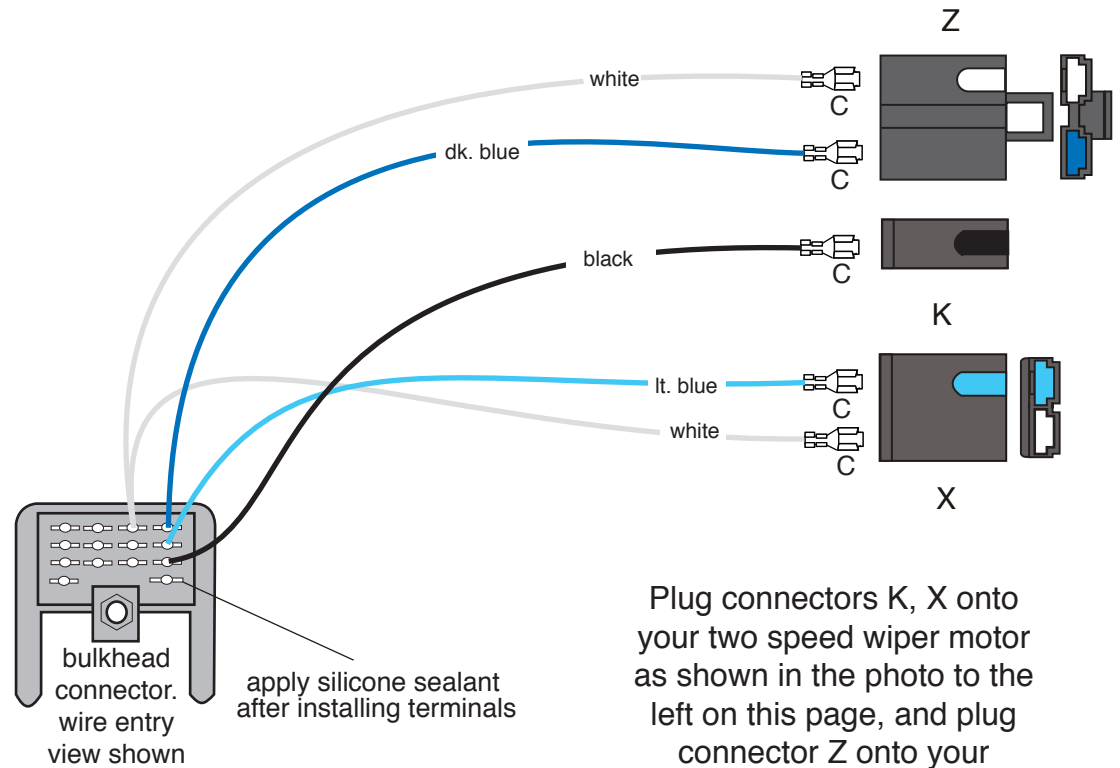

Plug connectors K, X onto your two speed wiper motor as shown in the photo to the left on this page, and plug connector Z onto your washer pump assembly.

WHITE (wiper feed)
(original black/yellow in photo)

Route the short white wire to the wiper motor, trim to length, install terminal C, and plug into connector X as shown on this page. Route the long white wire to the washer pump, trim to length, install terminal C, and plug into connector Z as shown on this page.

BLACK (wiper low speed)
(original black in photo)

Route this wire to the wiper motor, trim to length, install terminal C, and plug into connector K as shown on this page.

LT. BLUE (wiper high speed)
(original lt. blue in photo)

Route this wire to the wiper motor, trim to length, install terminal C, and plug into connector X as shown on this page.

DK. BLUE (washer)
(original dk. blue in photo)

Route this wire to the washer pump, trim to length, install terminal C, and plug into connector Z as shown on this page.

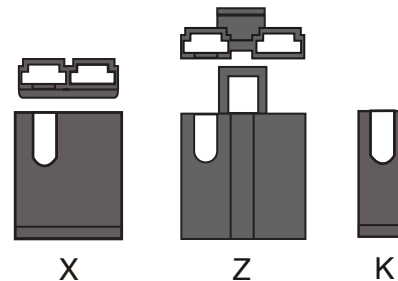

1975 - 78 TWO SPEED WITH WASHER PUMP CONNECTIONS



ENGINE KIT
510570

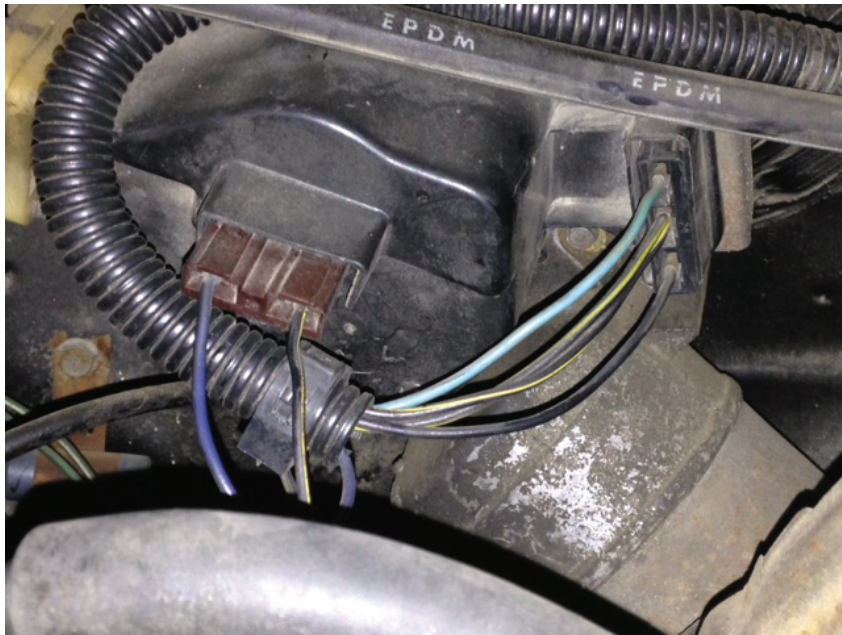

1979-1980 Camaro models with 2 speed wipers and washers

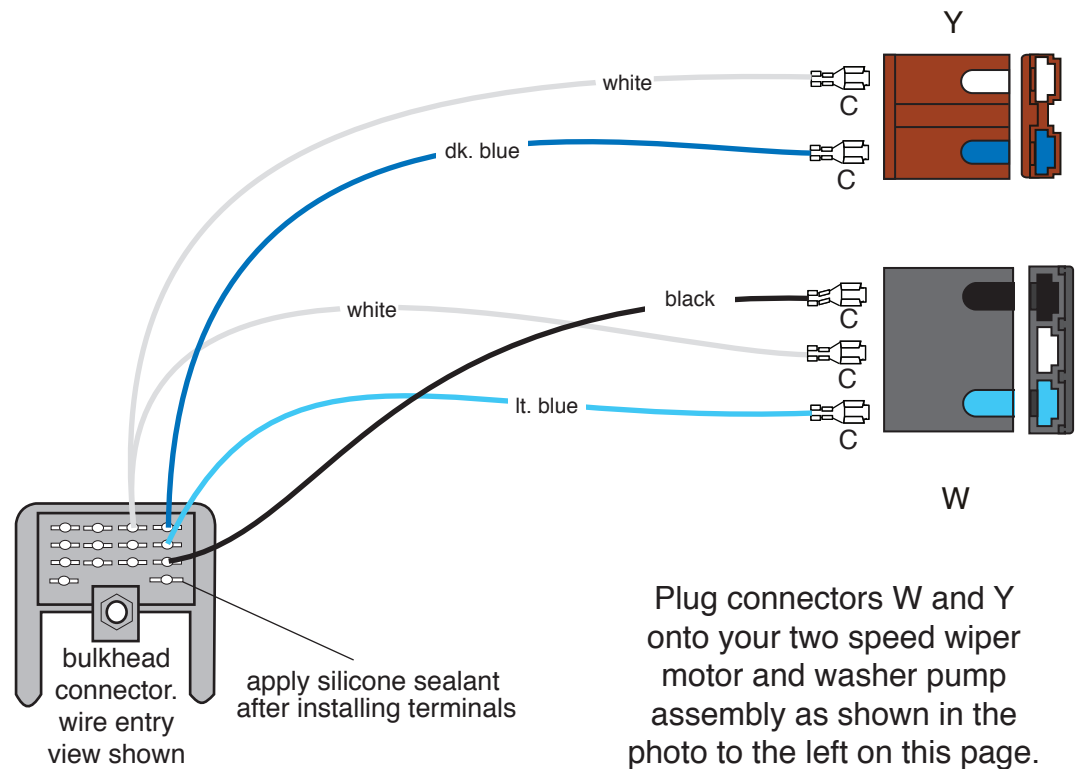

WHITE (wiper feed)
(original black/yellow in photo)

Route the short white wire to the wiper motor, trim to length, install terminal C, and plug into connector W as shown on this page. Route the long white wire to the washer pump, trim to length, install terminal C, and plug into connector Y as shown on this page.

BLACK (wiper low speed)
(original black in photo)

Route this wire to the wiper motor, trim to length, install terminal C, and plug into connector W as shown on this page.

LT. BLUE (wiper high speed)
(original lt. blue in photo)

Route this wire to the wiper motor, trim to length, install terminal C, and plug into connector W as shown on this page.

DK. BLUE (washer)
(original dk. blue in photo)

Route this wire to the washer pump, trim to length, install terminal C, and plug into connector Y as shown on this page.

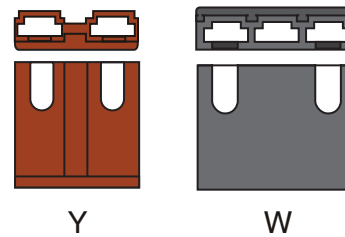

1979 - 80 TWO SPEED WITH WASHER PUMP CONNECTIONS



ENGINE KIT
510570

THIS PAGE HAS BEEN
INTENTIONALLY LEFT BLANK



www.americanautowire.com 856-933-0801

ENGINE KIT
510570

92970835 instruction rev 2.0 1/10/2018